



# PECAN SQUARE RESIDENTIAL DESIGN GUIDELINES

NORTHLAKE, TX  
APRIL 2022

# EXTERIOR PAINT COLORS

## COLORS & TONES

The color palettes shown are an illustrative range of color schemes typically approved by the Developer; other color schemes may be submitted.

- Paint, stucco, and brick colors must be submitted and approved by the Developer.
- All home colors shall be appropriate to the home style.
- Bright and primary colors are typically not approved by the Developer and shall be avoided.
- When appropriate to the design, the brick may be painted.
- MEP stacks, vents, and other wall/roof penetrations shall have a matte baked-on finish, and the color shall match the abutting wall/roof material.
- Accent colors usage shall be limited to doors, windows, shutters, projecting bays, and awnings appropriate to the home style.
- When light-tone neutral colors are used for the primary home color, accent colors shall be limited to medium-tone or dark-tone neutral colors.
- When medium-tone neutral colors are used for the primary home color, accent colors shall be limited to light-tone neutral colors.
- When dark-tone neutral colors are used for the primary home color, accent colors shall be limited to light-tone neutral colors.

### PROHIBITED COMBINATIONS **NO**



### PERMITTED COMBINATIONS **YES**



# PRIVACY SCREENINGS

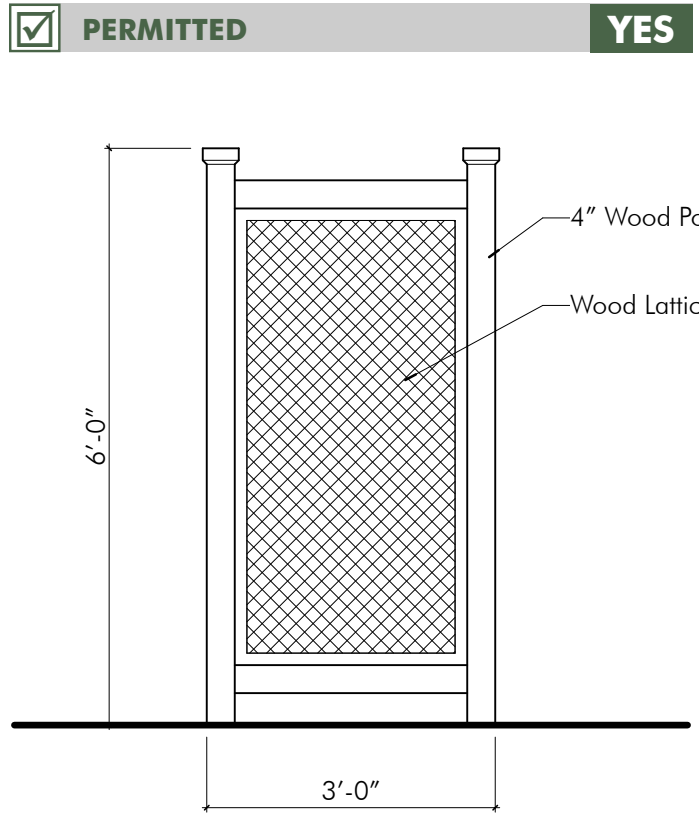

# TRELLIS

 **PROHIBITED**

**NO**



*Plastic lattice is not acceptable.*

 **PERMITTED**

**YES**

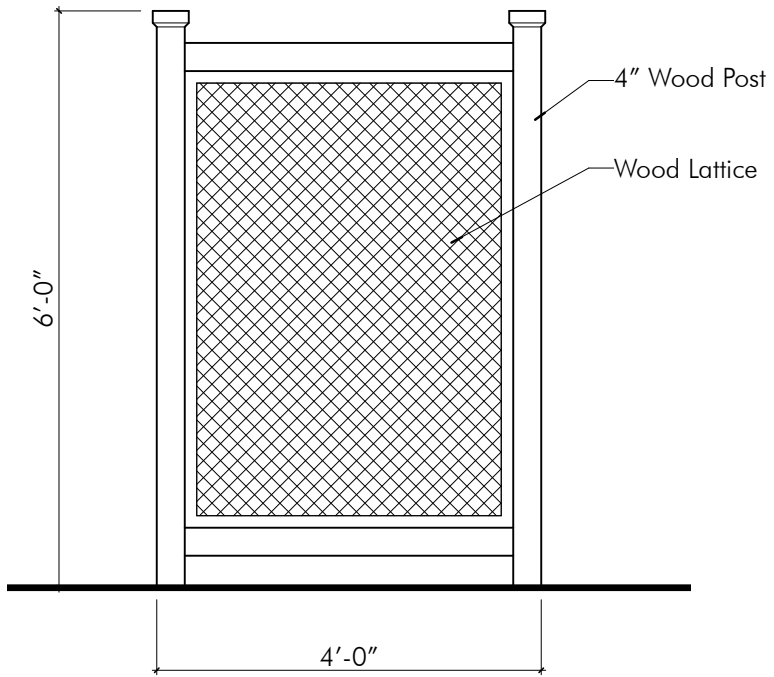

# PERGOLAS

 **PROHIBITED**

**NO**



 **PERMITTED**

**YES**

CLASSIC PERGOLA



*Freestanding structures in the back yard are permitted pending approval from ARC; must submit design, height, and distance to fence.*

# GAZEBOS

 **PROHIBITED**

**NO**

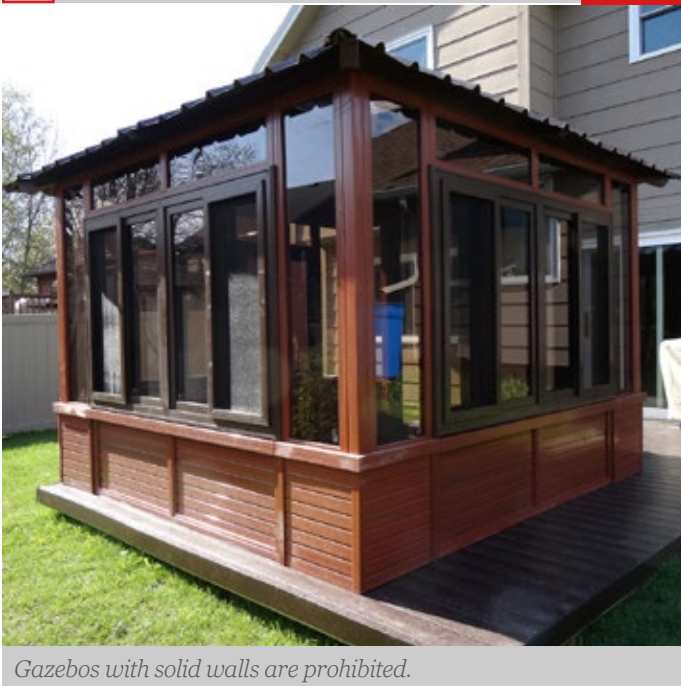

 **PERMITTED**

**YES**



*Freestanding structures with a shingle or metal roof are permitted pending approval from ARC; must submit design, height, and distance to fence.*

# ARBORS

**PROHIBITED**

**NO**



*Plastic Arbors are prohibited.*

**PERMITTED**

**YES**

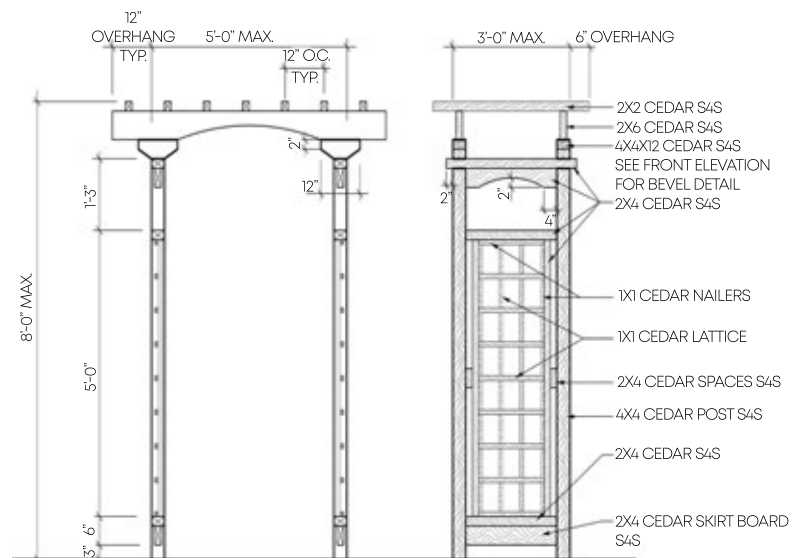
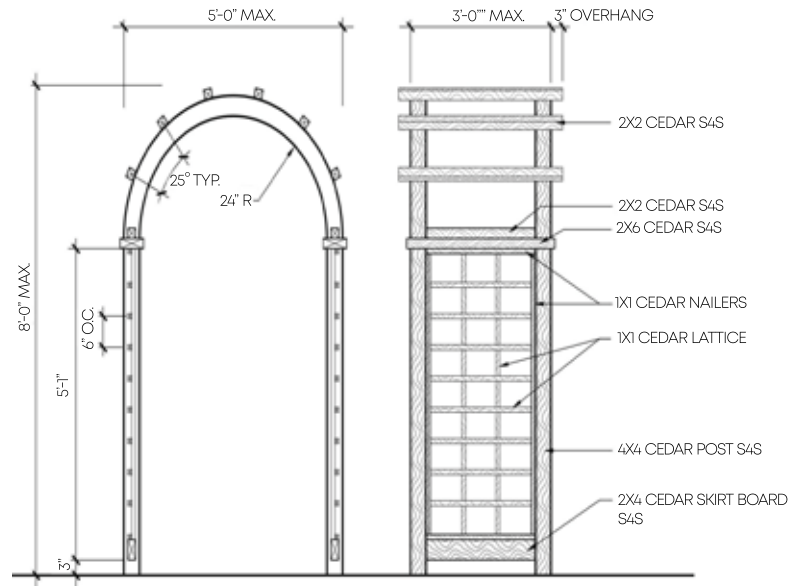

# REFUSE & A/C SCREENING

 **PROHIBITED**

**NO**



*A/C unit must be appropriately screened.*

 **PERMITTED**

**YES**



*Where home spacing is too tight, a single 4ft tall vertical picket screen may be permitted. The screen should be stained to match the fence.*

# SCREEN DOORS

**PROHIBITED** **NO**



Storm doors with horizontal or vertical grids are not acceptable.



Storm doors with horizontal or vertical grids are not acceptable.



Storm doors with horizontal or vertical grids are not acceptable.



Decorative screen doors must be pre-approved.

**PERMITTED** **YES**



Storm doors without horizontal or vertical grids are permitted

# SHUTTERS

**PROHIBITED** **NO**

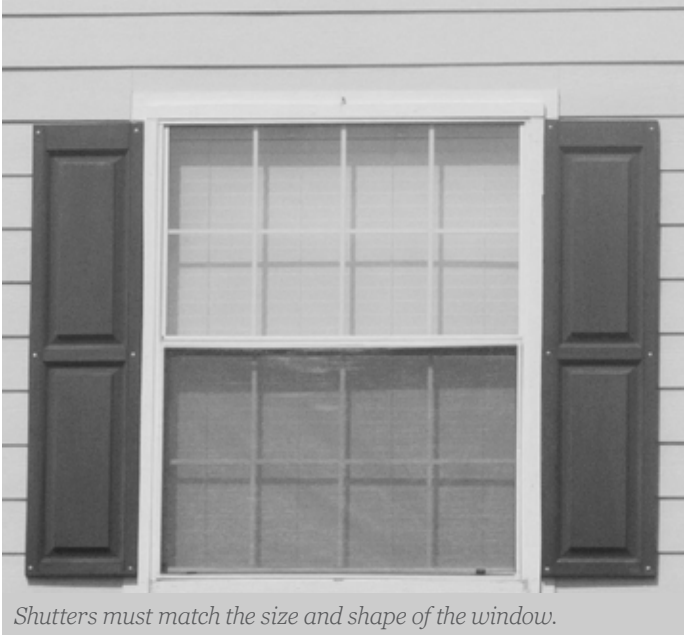

Shutters must match the size and shape of the window.

**PERMITTED** **YES**



Correctly sized shutters covered entirety of window when shut.



# SOLAR SCREENS

 **PROHIBITED**

**NO**



*Solar Screens must be consistent with existing window mullion spacing.*

 **PERMITTED**

**YES**



*Solar Screens must match the window trim color and mullion spacing.*

# SOLAR PANELS

 **PROHIBITED**

**NO**



*Ground-mounted solar panels are not permitted.*

 **PERMITTED**

**YES**



*Solar Panels are permitted on the home's rear roof line.*

# EAVE LIGHTING

**PROHIBITED** **NO**



*Eave lighting that is overly bright is prohibited.*



*Colored up lighting, coach lighting, and eave/down lighting is prohibited. Colored lighting is only permitted for Christmas lighting and may be installed 30 days prior to the holiday.*

**PERMITTED** **YES**



*Eave lighting is appropriately spaced with the correct level of brightness, and is in the appropriate range of color temperature.*

# COACH LIGHTING

**PROHIBITED** **NO**



*Coach lights do not match Architectural style.*



*Coach lights are too small.*



*Coach lights do not match Architectural style.*



*Security cameras cannot be mounted in conflict with lighting.*

**PERMITTED** **YES**



*Light fixtures are the appropriate size and match the style of the home.*

# ADDRESS/ NAME PLAQUES

**PROHIBITED**

**NO**



Address numbers must have a background plaque.

**PERMITTED**

**YES**



Address plaques are permitted. If there is an existing cast stone address, the plaque must fully cover over the existing address and the design of the numbers and plaque must match the style of the home.



Name plaques are permitted and should be located on the inside of stoop entrances by the front door.

# SIDEWALKS

**PROHIBITED**

**NO**



Crushed stone sidewalks are prohibited.

**PERMITTED**

**YES**



A paver edge to a concrete walk is permitted. Stone pavers are allowed as a concrete sidewalk replacement.

# LANDSCAPING BORDERS

**PROHIBITED**



Wood borders are prohibited.



Rolled plastic edging is prohibited.



Rolled plastic edging is prohibited.



Scalloped concrete borders are prohibited.



Scalloped concrete borders are prohibited.

**NO**

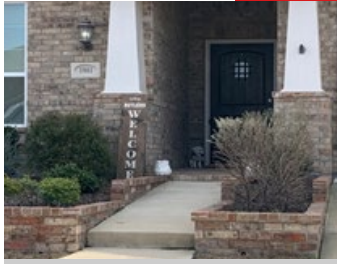

Brick borders must match brick on home exactly.



Faux Brick borders are prohibited.



Wood borders are prohibited.



Scalloped concrete borders are prohibited.



Landscape borders must be consistent in style.

**PERMITTED**

**YES**



Stone borders match the stone on the home.



Stone & brick combination border match the home.



Metal borders are permitted



Metal borders are permitted



Metal borders are permitted



Stone borders match the home.



Brick borders match the style of the home.

# ABOVE GROUND POOLS

**PROHIBITED**

**NO**



*Metal or Plastic tank pools are prohibited.*



*Metal or Plastic tank pools are prohibited.*

**PERMITTED**

**YES**



*High level of finish pool is allowed but must be submitted to the ARC for approval.*



*High level of finish pool is allowed but must be submitted to the ARC for approval.*

# IN-GROUND POOLS

**PROHIBITED**

**NO**



*Metal or plastic tank pools are prohibited as permanent pools.*

**PERMITTED**

**YES**

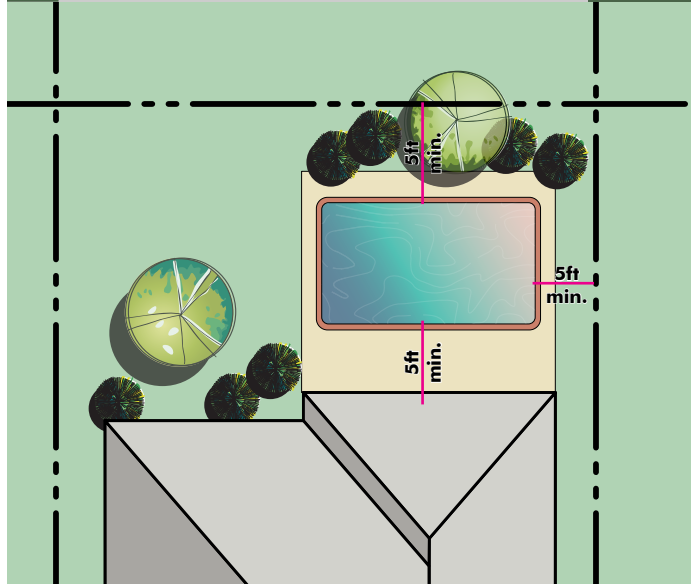

*Pools must be located 5 feet min. from house foundation, side yard property line, and rear yard property line. A property access plan must be submitted.*

# SHINGLES

 **PROHIBITED**

**NO**



*3-Tab shingles are not permitted.*



*3-Tab shingles are not permitted.*

 **PERMITTED**

**YES**



*Architectural shingles are permitted; shingle color must be approved.*



# FLAG POLES

PROHIBITED

**NO**



*Flag poles must be appropriate to the home and lot size. 20ft max.*

PERMITTED

**YES**



*Only U.S. and Texas flags are permitted.*



*Odd angled poles are prohibited.*



*Multiple flags on a single pole are prohibited.*



*Only U.S. and Texas flags are permitted.*